

TECHNICAL MANUAL

**TECHNICAL MANUAL
TRANSPORTABILITY GUIDANCE
TRACTOR-SCRAPER, WHEELED, M621B
14-CUBIC-YARD CAPACITY, COMMERCIAL CONSTRUCTION
EQUIPMENT
(NSN 3805-01-153-1854)**

TRANSPORTABILITY GUIDANCE

TRACTOR-SCRAPER, WHEELED, M621B

**14-CUBIC-YARD CAPACITY, COMMERCIAL CONSTRUCTION EQUIPMENT
 (NSN 3805-01-153-1854)**

TABLE OF CONTENTS

	<i>Paragraph</i>	<i>Page</i>
Chapter 1. INTRODUCTION		
Purpose and Scope	1-1	1-1
Safety	1-2	1-1
Definitions of Warnings, Cautions, and Notes	1-3	1-1
Reporting of Publication Improvements	1-4	1-1
Chapter 2. TRANSPORTABILITY DATE		
Section I. GENERAL		
Scope	2-1	2-1
Description	2-2	2-1
Transportability Drawings	2-3	2-1
II. CHARACTERISTICS AND RELATED DATA		
General Transportability Characteristics	2-4	2-1
Unusual Characteristics	2-5	2-6
Hazardous and Dangerous Characteristics	2-6	2-6
Chapter 3. SAFETY		
General	3-1	3-1
Specific Safety Requirements	3-2	3-1
Chapter 4. AIR TRANSPORTABILITY GUIDANCE,	4-1	4-1
Chapter 5. HIGHWAY TRANSPORTABILITY GUIDANCE		
Section I. GENERAL		
Scope	5-1	5-1
Safety	5-2	5-1
General	5-3	5-1
II. TRANSPORT BY SEMITRAILER		
Transport of Tractor-Scraper, M621 B by Semitrailer.	5-4	5-1
Preparation of Tractor-Scraper	5-5	5-1
Transport of Tractor-Scraper, M621B on M870 Semitrailer Towed by M920 Truck Tractor	5-6	5-1
Chapter 6. MARINE AND TERMINAL TRANSPORTABILITY GUIDANCE		
Section I. GENERAL		
Scope	6-1	6-1
Safety	6-2	6-1
Water Shipment	6-3	6-1
II. LOADING AND SECURING		
General Rules for Stowing	6-4	6-1
Barges and Lighters	6-5	6-5
Landing Ships, Landing Craft, and Amphibious Vehicles	6-6	6-5
Chapter 7. RAIL, TRANSPORTABILITY GUIDANCE		
Section I. GENERAL		
Scope	7-1	7-1
Maximum Utilization of Railcars	7-2	7-1
Section I I TRANSPORT ON CONUS RAILWAYS		
General	7-3	7-1
Preparation for Loading	7-4	7-1
Loading of Tractor-Scraper on General-Purpose Flatcars.	7-5	7-1
III. TRANSPORT ON FOREIGN RAILWAYS		
General	7-6	7-3
Transport on Foreign-Service Flatcars	7-7	7-3
Appendix References..		A-1

CHAPTER 1

INTRODUCTION

1-1. Purpose and Scope.

a. This manual provides transportability guidance for logistical handling and movement of the tractor-scraper, wheeled, M621B. It contains information considered appropriate for safe transport of the item. Included are significant technical and physical characteristics with safety considerations required for worldwide movement by the various transportation modes. Where needed, metric equivalents are given in parentheses after the US dimensions.

b. This manual is intended for transportation officers and other personnel responsible for movement or transportation services.

1-2. Safety.

Appropriate precautionary measures required during movement of the item are contained in chapter 3.

1-3. Definitions of Warnings, Cautions, and Notes.

When used in this manual, warnings, cautions,

and notes emphasize important or critical guidance. They are used for the following conditions:

a. *Warning.* Instructions that, if not followed, could result in injury to or death of personnel.

b. *Caution.* Instructions that, if not strictly observed, could result in damage to or destruction of equipment.

c. *Note.* An operating procedure that must be emphasized.

1-4. Reporting of Publication Improvements.

Users of this manual are encouraged to recommend changes and submit comments for its improvement. Comments should be prepared on DA Form 2028 (Recommended Changes to Publications and Blank Forms) and sent to Commander, Military Traffic Management Command Transportation Engineering Agency, ATTN: MT-T-TRC, P.O. Box 6276, Newport News, VA 23606-0276. Electrically transmitted comments should be addressed to CDR MTMCTEA FT EUSTIS VA//MTT-TRC//.

CHAPTER 2

TRANSPORTABILITY DATA

Section I. GENERAL

2-1. Scope.

This chapter provides a general description and identification photographs of the M621B tractor-scraper, as well as tabulated transportability characteristics that are necessary for movement of the item.

2-2. Description.

The M621B tractor-scraper is a wheeled, commercial construction, open-bowl-type vehicle with two axles. The tractor section has two pneumatic rubber-tired driving wheels powered by a single diesel engine rated at 330 horsepower. The scraper section is towed by the tractor section and has two pneumatic rubber tires on free-turning wheels. The articulated steering is hydraulically operated, and a steering lock is provided for use when the vehicle is transported. The hitch between the two sections is noncushioned. The only contact with the ground is the four tires, except for the scraper bowl, when it is used to scrape, and the cutting edge, when the tractor-scraper is parked. The transmission is an eight forward speed, semiautomatic power shift with a foot-pedal-engaged differential lock. The brakes are air-actuated, expanding shoe-type. The park brake is on when air is removed.

vided for use when the vehicle is transported. The hitch between the two sections is noncushioned. The only contact with the ground is the four tires, except for the scraper bowl, when it is used to scrape, and the cutting edge, when the tractor-scraper is parked. The transmission is an eight forward speed, semiautomatic power shift with a foot-pedal-engaged differential lock. The brakes are air-actuated, expanding shoe-type. The park brake is on when air is removed.

2-3. Transportability Drawings.

Detailed side- and end-elevation transportability drawings of the M621B tractor-scraper, with dimensions and tiedown and lift-provision load-rating capacities, are shown in figures 2-2 through 2-4.

Section II. CHARACTERISTICS AND RELATED DATA

2-4. General Transportability Characteristics.

These data are applicable to the model number or national stock number (NSN) shown. Changes in the model number or NSN may affect the loadability of the item as related to guidance shown in this manual.

a Tractor Scraper, Wheeled, M621B.

National stock number. . . . 3805-01-153-1854

Line item number. S56246

Ground pressure (each tire at 35 and 45 psi inflation pressure):

Unloaded (curb weight)

Front . .42.8 to 50.3 psi (295.1 to 346.8 kPa)

Rear.. .36.4 to 39.8 psi (250.9 to 275.1 kPa)

Ground contact area (each tire at 35 and 45 psi inflation pressure):

Front 515 to 441 in² (0.332 to 0.285 m²)

Rear 275 to 248 in² (0.177 to 0.160 m²)

Tire type..... 29.5 x 29, 28 ply, E-2, traction type

Pressure:

Front and rear .35 to 45 psi (241.3 to 310.3 kPa)

Axle Load:

Front axle.. 44,098 lb (20 002 kg)

Rear axle.. 19,812 lb (8987 kg)

Performance:

Maximum speed (eight range) . . 31 mph (50 km/h)

Range (empty at 15 mph) . . . 176 miles (186 km)

Fuel tank capacity. . .135 US gal (510 liters)

Turning radius36.5 ft. (11.12 m)

Angle of approach17°

Angle of departure.14°

Ground clearance 18.5 in. (0.47 m) with bowl raised

Dimensions and shipping data:

Length, operational 499 in. (12.67 m)

Width, tractor, operational. 116 in. (2.95 m)

Width, scraper, operational. 136 in. (3.45 m)

Tread width, tractor 87 in. (2.21 m)

Tread width, scraper. 86 in. (2.19 m)

Height, operational.. . . . 142 in. (3.61 m)

Area, operational 471.28 ft² (43.71 m²)

Cube, operational. . .5,616.06 ft³ (159.03 m³)

Center of gravity:

Above ground..51.9 in. (1.32 m)

From centerline of scraper wheel . .207.9 in. (5.23 m)

Weights:

Shipping (with fuel and liquids full). 63,910 lb (28 989 kg)



Figure 2-1. Tractor-scraper, wheeled M621B.

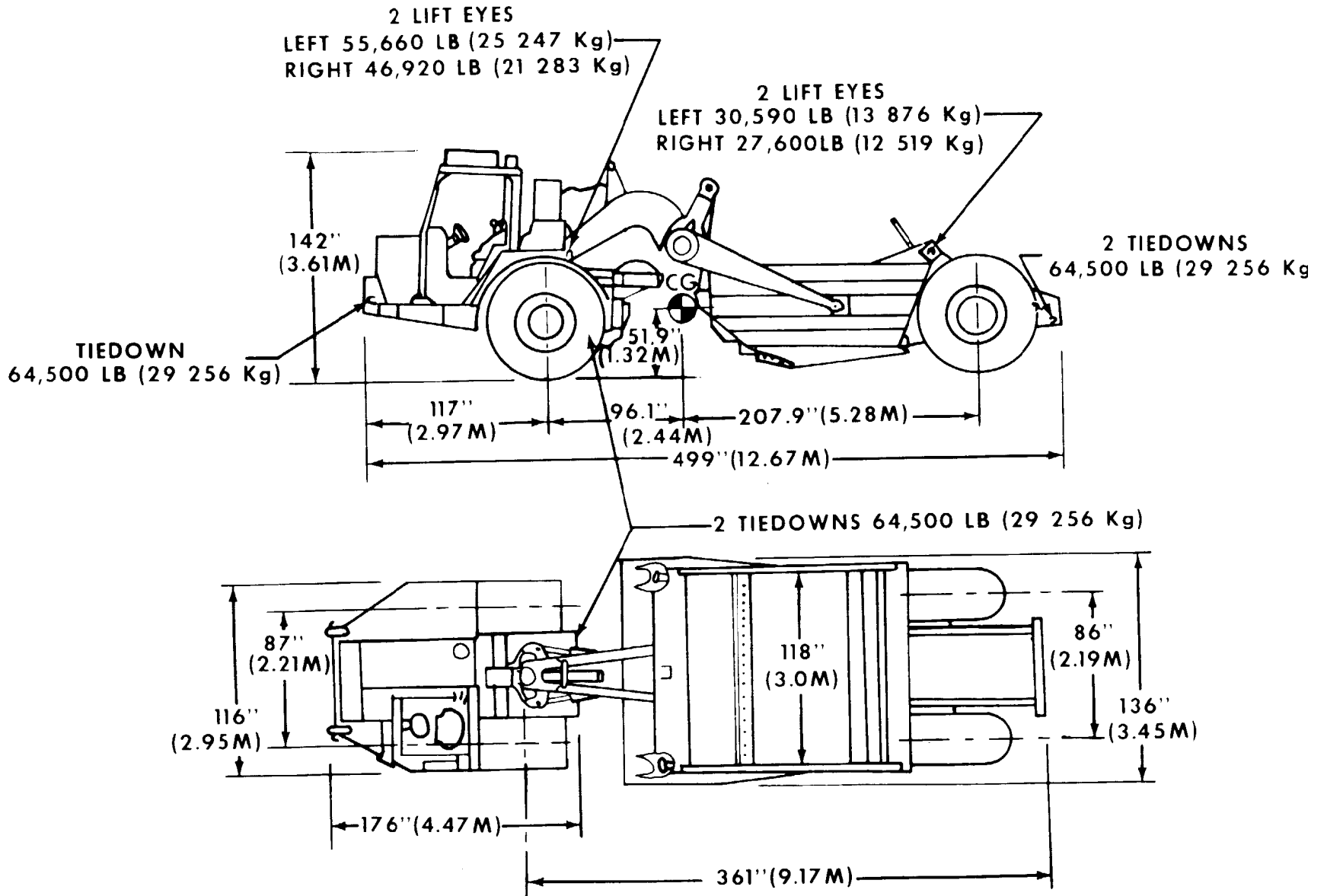

Figure 2-2. Side and top views of tractor-scraper, wheeled, M621B.

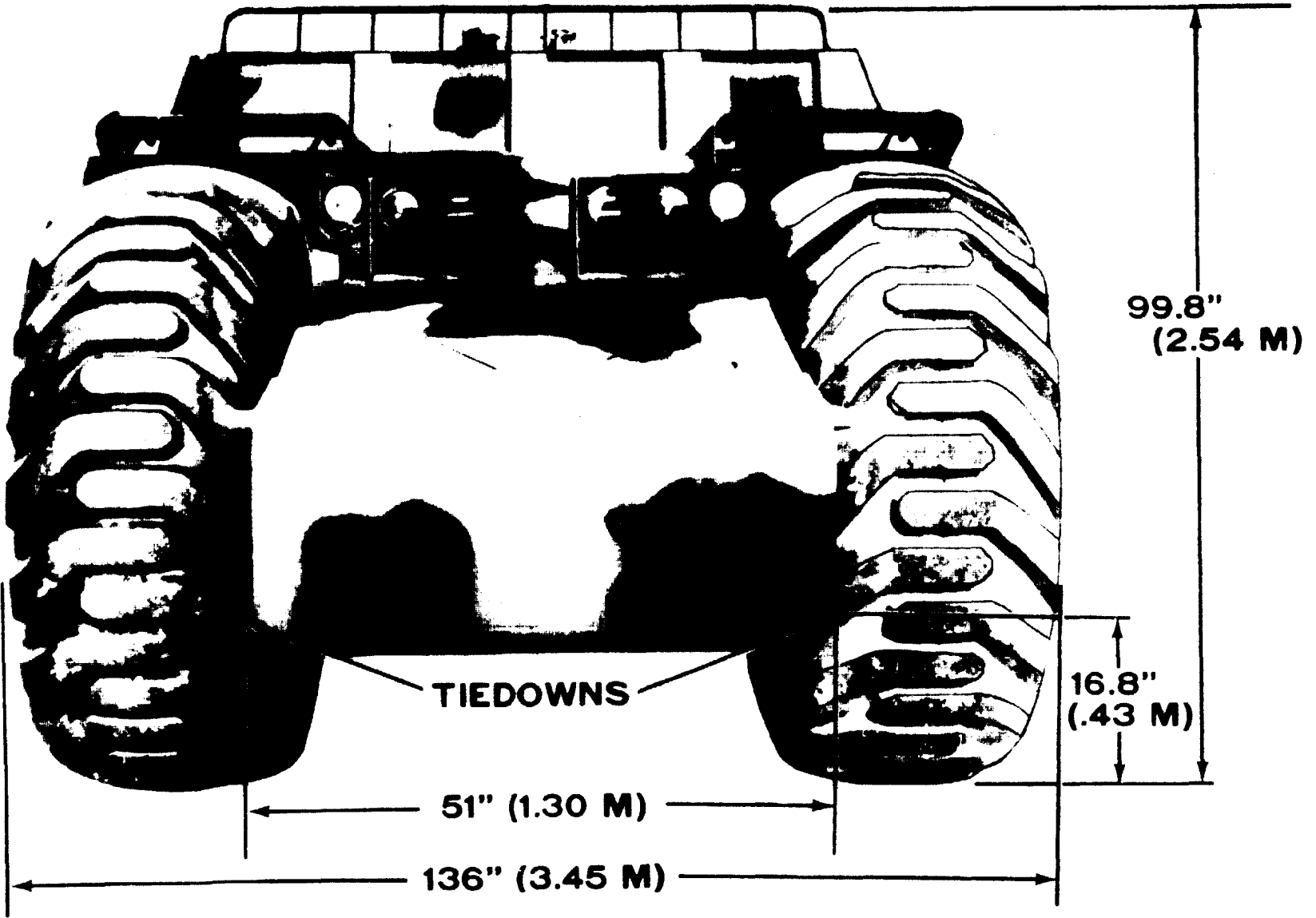
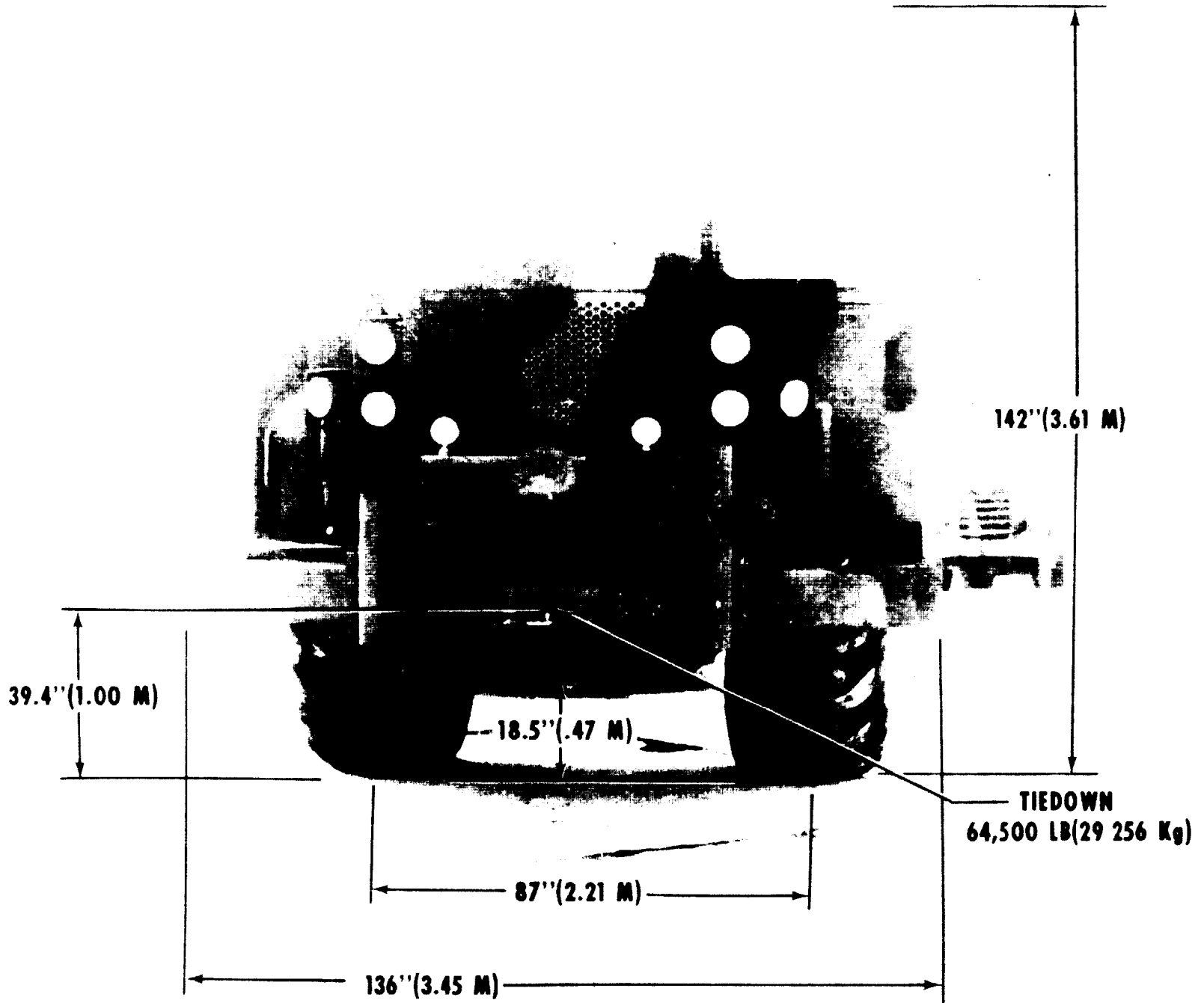

Figure 2-3. Rear view of tractor-scraper, wheeled M621B.

Figure 2-4. Front view of tractor-scraper, wheeled, M621B.



With rollover protective structures/falling object protective structure and integral cab removed 62,910 lb (28 536 kg)

Capacity:

Struck 14 yd³ (10.70 m³)

Heaped 20 yd³ (11.50 m³)

Rated load 48,000 lb (21 772.8 kg)

Military load classification (MLC):

Empty MLC 75

Loaded (24-ton payload) MLC 93

2-5. Unusual Characteristics.

This vehicle has no unusual characteristics that would require that special attention be given to

temperature, atmospheric pressure, or humidity variations during its exposure to normal transportation environments.

2-6. Hazardous and Dangerous Characteristics.

The vehicle has no special hazardous or dangerous characteristics during its exposure to normal transportation environments,

NOTE

Those regulations and/or transportation procedures normally associated with vehicles containing diesel fuel will apply.

CHAPTER 3

SAFETY

3-1. General.

General safety considerations and precautions for movement are as follows:

a. Each vehicle must be checked to ensure all loose items are secured in accordance with applicable regulations (Supplemental Operator's Maintenance and Repair Parts Instruction, SOMARPI 5-3805-248).

b. The vehicle must be driven by qualified drivers only.

c. When the vehicle is driven, the driver's cab door must be closed.

d. Drivers must not leave the operator's position while the engine is running.

e. When the vehicle is in motion, it must not be mounted or dismounted.

f. Personnel must not ride on the vehicle.

g. The seat belt will be fastened during vehicle operation.

h. Personnel must not smoke when operating

or refueling the vehicle.

i. The driver must bring the vehicle to a complete stop before driving in or out of a building.

j. Whenever the vehicle is operated in reverse, a ground guide must be used to direct the driver.

k. Personnel must stay clear of the engine exhaust area during and immediately after engine operation. Contact with these areas can cause severe burns.

l. The engine must not be operated in an enclosed area without adequate ventilation to provide sufficient air for engine combustion as well as dissipation of exhaust gases.

3-2. Specific Safety Requirements.

Pertinent safety requirements by individual mode are given, where applicable, in the appropriate chapters.

CHAPTER 4

AIR TRANSPORTABILITY GUIDANCE

The tractor-scraper, wheeled, M621R is not approved for transport by the air mode.

CHAPTER 5

HIGHWAY TRANSPORTABILITY GUIDANCE

Section I. GENERAL

5-1. Scope.

This chapter provides highway transportability guidance for the movement of the tractor-scraper, wheeled, M621B. It covers significant technical and physical characteristics, as well as safety concerns, and prescribes the materials and guidance required to prepare, load, tie down, and unload the vehicle.

5-2. Safety.

In addition to the safety precautions contained in chapter 3, movement is subject to all safety laws, rules, and regulations applicable to commercial carriers. Overseas, such movements are governed by theater regulations. Vehicle transmission must be placed in the neutral position and the park brake on (air removed).

CAUTION

Vehicle speed must not exceed 3 mph during loading or unloading.

5-3. General.

The vehicle is considered self-deliverable only under appropriate tactical conditions. The tractor-scraper, M621B, when empty, has a maximum range of 176 miles (283 km) and a maximum speed of 31 miles per hour (50 km/h).

Section II. TRANSPORT BY SEMITRAILER

5-4. Transport of Tractor-Scraper, M621B by Semitrailer.

When loaded on semitrailers, the tractor-scraper can be transported over highways; however, movement over public highways in CONUS and overseas should be made only when other transport modes cannot be used. When highway shipments must be made, this vehicle should be loaded onto military or commercial low-bed semitrailers of adequate capacity. In addition to the limitations and restrictions identified in paragraph 5-3, the height and weight limitations in CONUS and overseas are exceeded when the tractor-scraper is loaded on a semitrailer.

5-5. Preparation of Tractor-Scraper.

The vehicle will not be reduced, because removal

CAUTION

The tires of the tractor-scraper are not capable of withstanding excessive heat generated by extensive highway travel. This excessive heat can cause sudden tire failure. To drive an empty tractor-scraper for more than 20 highway miles, the front axle tires must be inflated to 55 psi and the rear axle tires deflated to 25 psi. Maximum highway speed should be limited to 20 mph. After 2 hours of sustained highway travel, the vehicle should stop for 30 minutes for a cooling period. After the second stop, or 4 hours total highway travel, the vehicle should stop for a 1-hour cooling period. For every 2 stops or every 4 hours of highway travel, the cycle should be repeated. For all other highway operations that do not meet the conditions described in this caution, the Goodyear Off-the-Road Department, telephone (216) 796-2010, Akron, Ohio should be contacted.

Movement over public highways will not be attempted without specific approval. The 136-inch width exceeds limitations in CONUS and overseas.

of the ROPS/FOPS cab only lowers the height 9 inches and lessens the weight 1,000 pounds.

5-6. Transport of Tractor-Scraper, M621B on M870 Semitrailer Towed by M920 Truck Tractor.

a. General. The combined length of the tractor and semitrailer (65 feet) exceeds the generally accepted CONUS and overseas standards. The height (195 inches or 16 feet, 3 inches) severely limits bridge clearance. Additionally, the width, tandem axle loads, and gross vehicle weight exceed highway limits in most countries. Where limits are exceeded, special permits and special routing are required.

b. Materials. The bill of materials for blocking and tiedown of the tractor-scraper on the M870 semitrailer is shown in table 5-1.

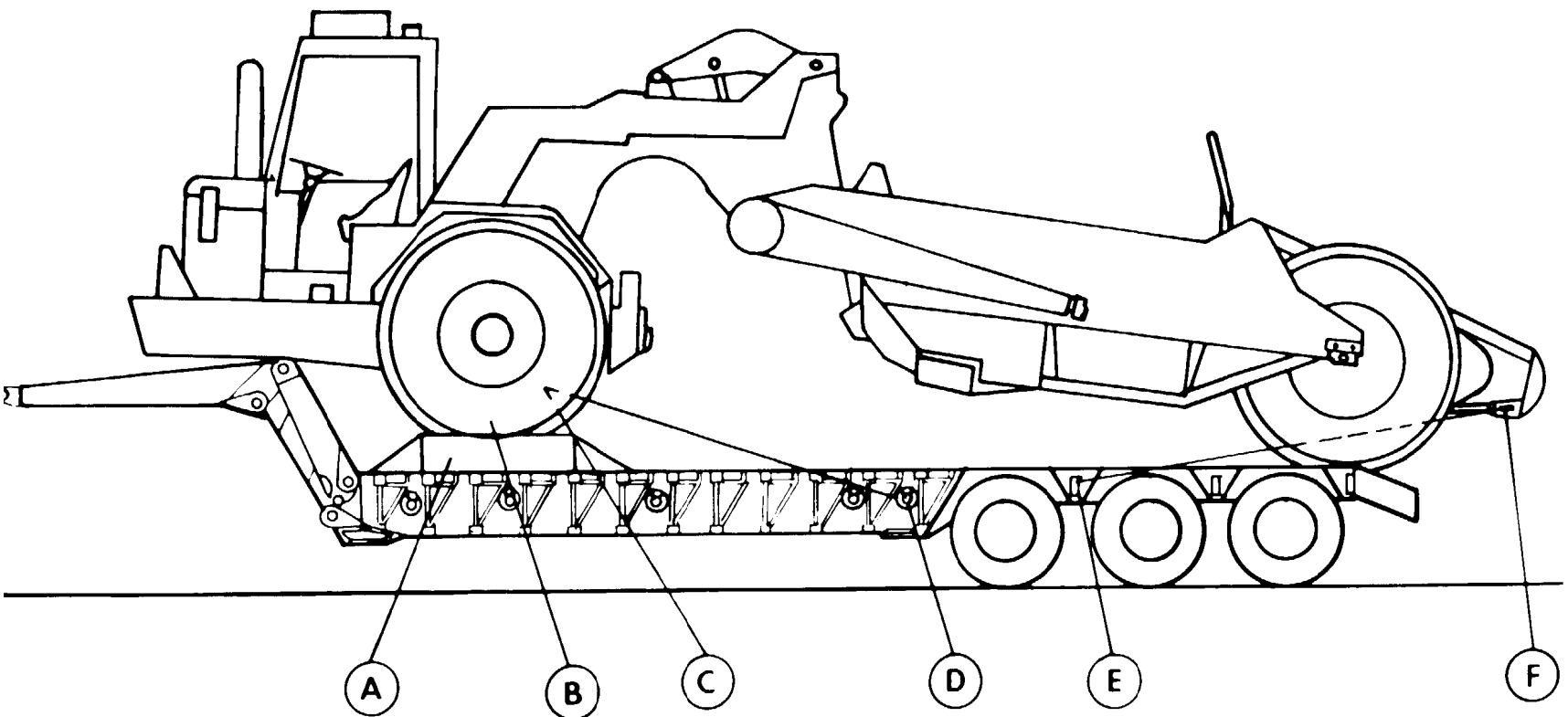

Figure 5-1. Tiedown diagram of the tractor-scraper on a semitrailer, M870.

c. Loading.

(1) The vehicle may be driven onto the semitrailer if a ramp is available or backed onto the semitrailer with the semitrailer gooseneck extended. However, should physical facilities and/or equipment preclude these loading methods, the vehicle may be lifted onto the semitrailer by a crane of sufficient capacity. For lifting procedures and precautions, see paragraph 6-46.

CAUTION

Since the wheel tread (tire width-outside to outside of tires) is 119 inches compared with a trailer width of 96 inches, about one-third of each tire will project beyond the sides of the trailer. Care must be taken to ensure an equal amount of tire overhang occurs on both sides.

(2) The tractor-scraper should be parked and the brakes should be on as shown in figure 5-1.

The rear axle of the scraper should be over the rear edge of the last trailer tire.

NOTE

The tire pressure of the tractor must be at least 45 psi because of the close clearance of the tractor cab over the trailer gooseneck.

(3) The M870 semitrailer gooseneck should be raised to the travel position by use of the truck-tractor winch cable, and the semitrailer should be connected to the M920 truck tractor.

(4) Data for the application of material required to restrain the vehicle are provided in table 5-2.

CAUTION

Before the semitrailer is moved, effect lockout of the tractor-scraper's steering/articulation unit by installing two locks on the steering cylinders.

Table 5-1. Bill of Materials for Blocking and Tiedown of the Tractor-Scraper, M621B on the MB70 Semitrailer.

Item	Description	Approximate Quantity
Parking Platform	Stacked 1-inch plywood, 96 inches wide, 13 sheets high. Construct to have a 45° slant on both wide edges by starting with a loose sheet 80 inches long. Cut each succeeding sheet 2 inches shorter. (i.e. second sheet 78 inches long, third sheet 76 inches long, etc.) This provides the 45° slants and a 1 inch nailing surface on both wide edges.	1
Sleeper Shoring/Lateral Blocking Chain Assembly*	6- x 6- x 50.inch lumber. Each consists of two. 120-inch-long ½-inch-diameter chains with hooks on each end (breaking strength, 45,000 pounds). (This type of chain is shown in the General Catalog of the Crosby Group Inc., PO Box 3128, Tulsa, OK 74101; or, in the catalog of McMaster-Carr Supply Company, PO Box 4355, Chicago, IL 60683.	9
Load Binders*	½-inch in diameter (breaking strength, 45,000 pounds).	4
Nails	Common, steel; flathead. bright or cement coated; para 3.6.11.2 Fed Spec FF-N-105B: 10d 20d	4 500 50

*Wire rope, 5/8-inch. 16 x 19, IWRC; improved plow steel; performed, regular-lay) clips and thimbles may be substituted for the chains and loadbinders.

Table 5-2. Application of Materials for Tiedown of Tractor-Scraper OR the M870 Semitrailer (fig 5-1).

Item	No. Required	Application
A	1	Parking platform. Place with a slanted edge forward against semitrailer gooseneck hinge point. Nail sheets to floor and each other with 10d nails.
B	9	Sleeper shoring/lateral blocking, 6- x 6- x 50.inch lumber. Place three abreast and stack three high between tractor wheels along the length of the semitrailer. Shore height to fit (approximately 18 inches to bottom of engine). Toenail to floor and to each other with 20d nails.
C, D, E, F		Connect all chains in complete loops to create double the breaking strength of the assemblies. Pass the chains through the vehicle tiedown devices and through the semitrailer outside tiedown ring on the same side. from C to D, and on the opposite side, from E to F. at an approximate 45° angle. Tighten the chains with the loadbinders.

CHAPTER 6

MARINE AND TERMINAL TRANSPORTABILITY GUIDANCE

Section I. GENERAL

6-1. Scope.

This chapter provides marine and terminal transportability guidance for movement of the tractor-scraper, M621B. It covers significant technical and physical characteristics, as well as safety concerns, and prescribes the materials and guidance required to prepare, load, tie down, and unload the vehicle.

6-2. Safety.

In addition to the safety precautions contained in chapter 3, the following areas apply:

- a. All vessel equipment and gear should be inspected before use.
- b. All stevedore slings and other items used in loading and unloading operations should be *checked for their conditions and capacity*.
- c. All other precautionary measures and safety regulations peculiar to the loading/unloading site or terminal will be adhered to.
- d. Vehicle fuel tanks must be drained and battery terminals must be disconnected.
- e. Vehicle transmission must be placed in the neutral position and the park brake on (air removed).

NOTE

When the tractor-scraper is loaded on vessels that are adequately ventilated by power blowers, such as those commonly found on the roll-on/roll-off (RORO) ships, fuel tanks need not be drained.

6-3. Water Shipment.

The tractor-scraper can be transported aboard US-flag merchant vessels, including Military Sealift Command ship, as follows:

- a. On or below decks of any breakbulk ship with a 30-long-ton lift capability. Required minimum hatch sizes and clear headroom are hatch length, 42 feet 6 inches; hatch width, 12 feet 4 inches; clear headroom, 12 feet 6 inches.
- b. On any RORO ship or trailership with clear deck heights of 12 feet 6 inches and ramp width of at least 13 feet 6 inches.
- c. In any SEABEE barge.

NOTE

The methods described in this chapter for lifting and securing the tractor-scraper are suggested procedures. Other methods of handling and stowage may be used to accomplish safe delivery without damage.

Section II. LOADING AND SECURING

6-4. General Rules for Stowing.

a. *General.* Whenever possible, vehicles should receive the protection of below-deck stowage. In general, good stowage of vehicles means vehicles are placed fore and aft as close together as practical, with minimum spacing between outer vehicles and the sweatboards - about 4 to 6 inches. Breakable parts or auxiliary equipment of the vehicles should be adequately protected and secured for shipment. Spare parts and OEM, if not shipped on the vehicle, should be properly identified as to location or disposition during the shipment. Vehicles in the ship's hold should be blocked in front, in rear, and on both sides of the wheels so that the vehicle cannot move in any direction; individual vehicle blocks should be braced to bulkheads, stanchions, and other vehicle blocks. Additionally, all vehicles should be

lashed with wire rope or chains to nearby padeyes, bulkheads, or stanchions.

b. *Lifting.* The correct lifting points on the vehicle are the lift eye provisions located on the rear top of the scraper and at either side of the gooseneck hinge pivot point. (See fig. 6-1).

CAUTION

Before the vehicle is lifted, effect lockout of the vehicle's steering/articulation unit by installing two blocks on the steering cylinders.

c. *Loading.* Prior to loading, fold the side mirror flush with the cab. The tractor-scraper can be loaded over the beach or from piers onto landing craft, landing ship tanks (LST), and landing ship docks (LSD) under its own power or by crane of adequate capacity. The vehicle can also be loaded under its own power onto the deck of barges from pierside when tidal conditions are

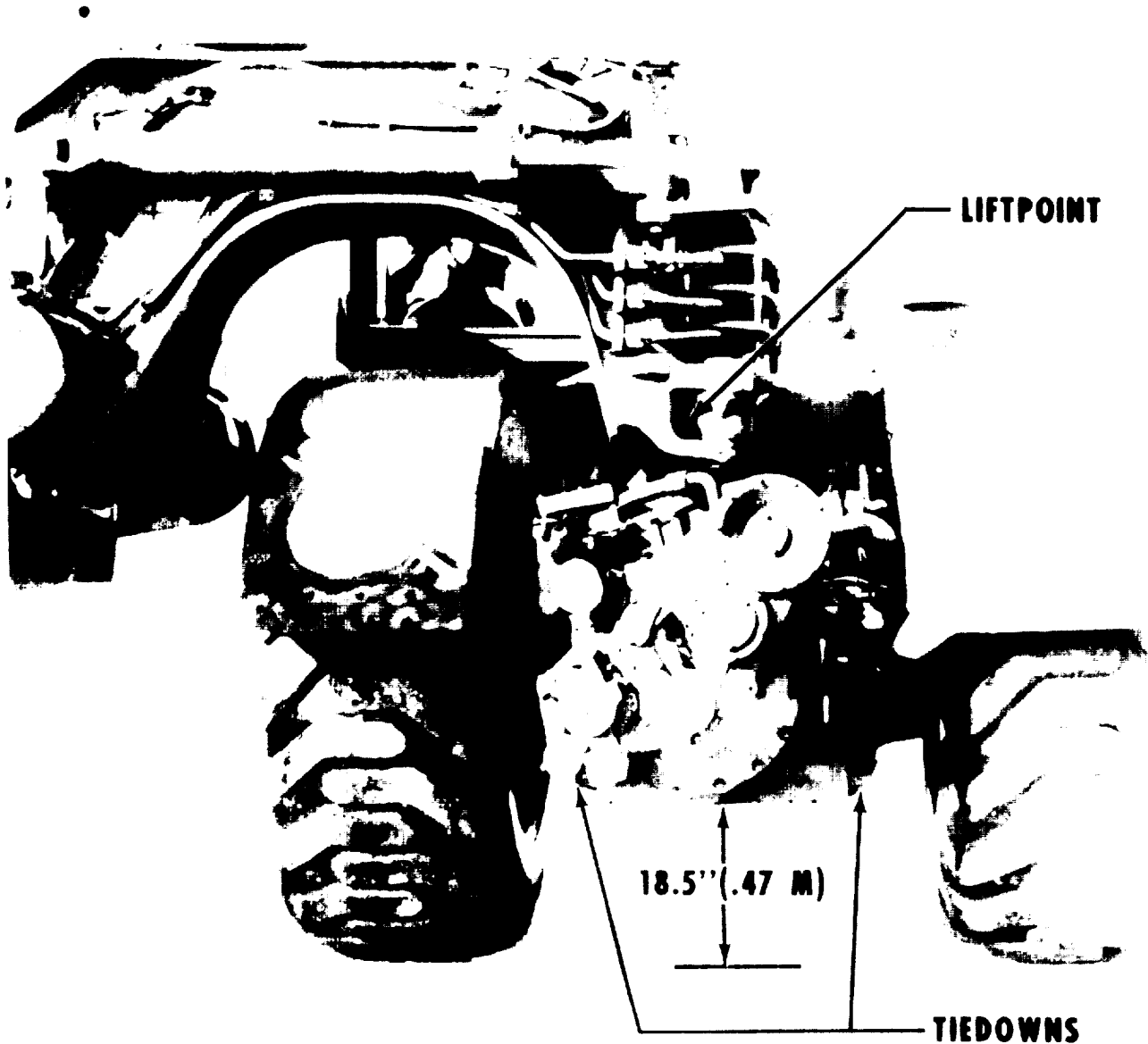

Figure 6-1. Tractor-Scraper front lift points and tiedown points

suitable and ramps are available. The vehicle can be loaded onto seagoing vessels by shoreside or floating cranes of adequate capacity. Jumbo booms and heavy-lift ship's gear may be used in loading vehicles on vessels. The vehicle can also be loaded on RORO vessels either under its own power or by towing.

d. Materials.

(1) Table 6-1 is the approximate bill of materials for blocking and tiedown of a tractor-scraper in the hold of a general-cargo vessel. Required amounts will vary as to type of vessel configuration and location aboard the vessel.

(2) Figure 6-3 shows typical blocking and tiedown details of a tractor-scraper in the hold of a general-cargo vessel.

(3) Table 6-2 provides data concerning the application of materials required to restrain the vehicle.

e. Special Design. Seatrain trailer vessels, RORO vessels, landing ships, and attack cargo vessels are equipped with patented lashing gear and pre-positioned fittings in the deck. This onboard restraint equipment is considered adequate for the tractor-scraper and no further blocking or bracing is required.

Figure 6-2: Lifting diagram for tractor-scraper.

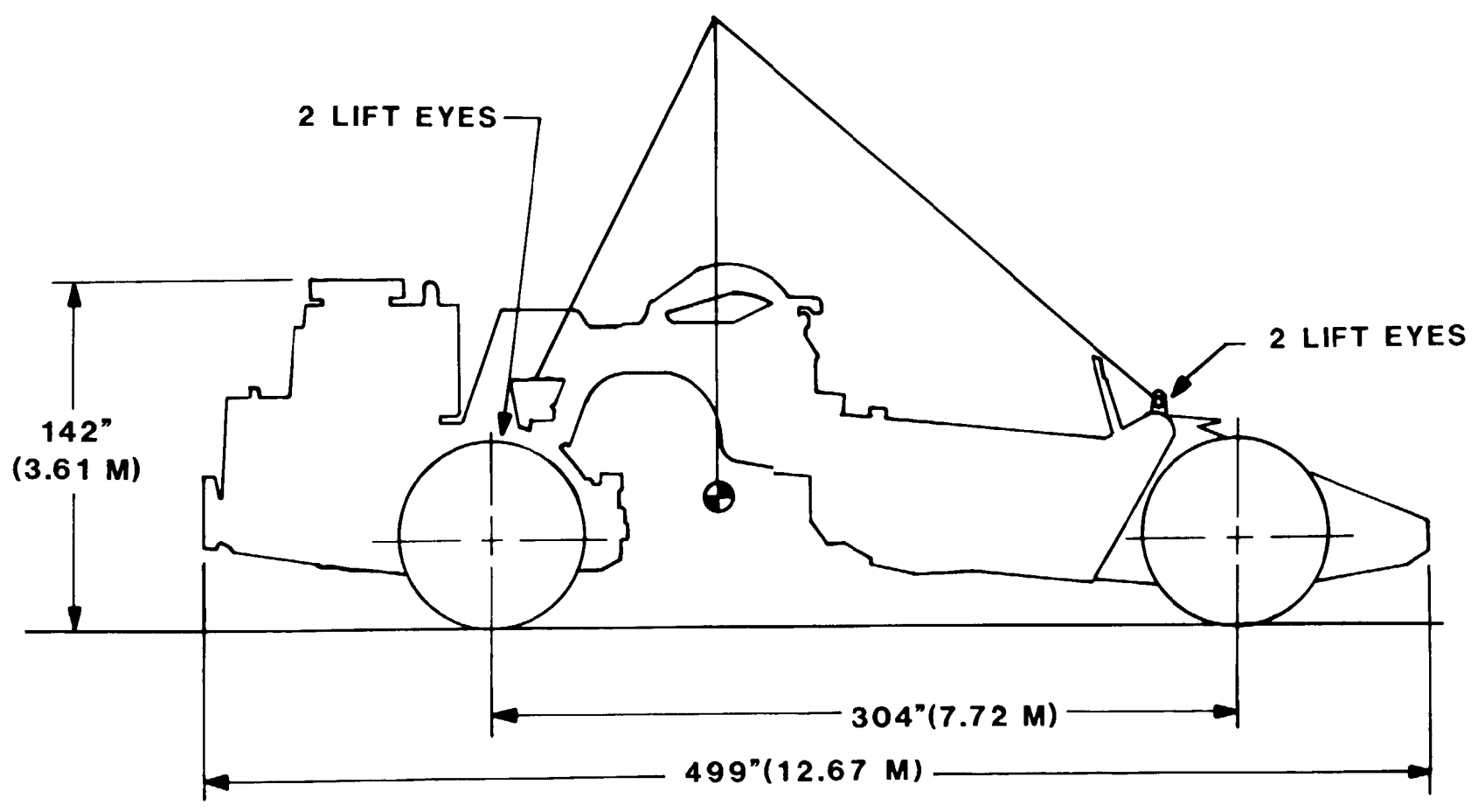

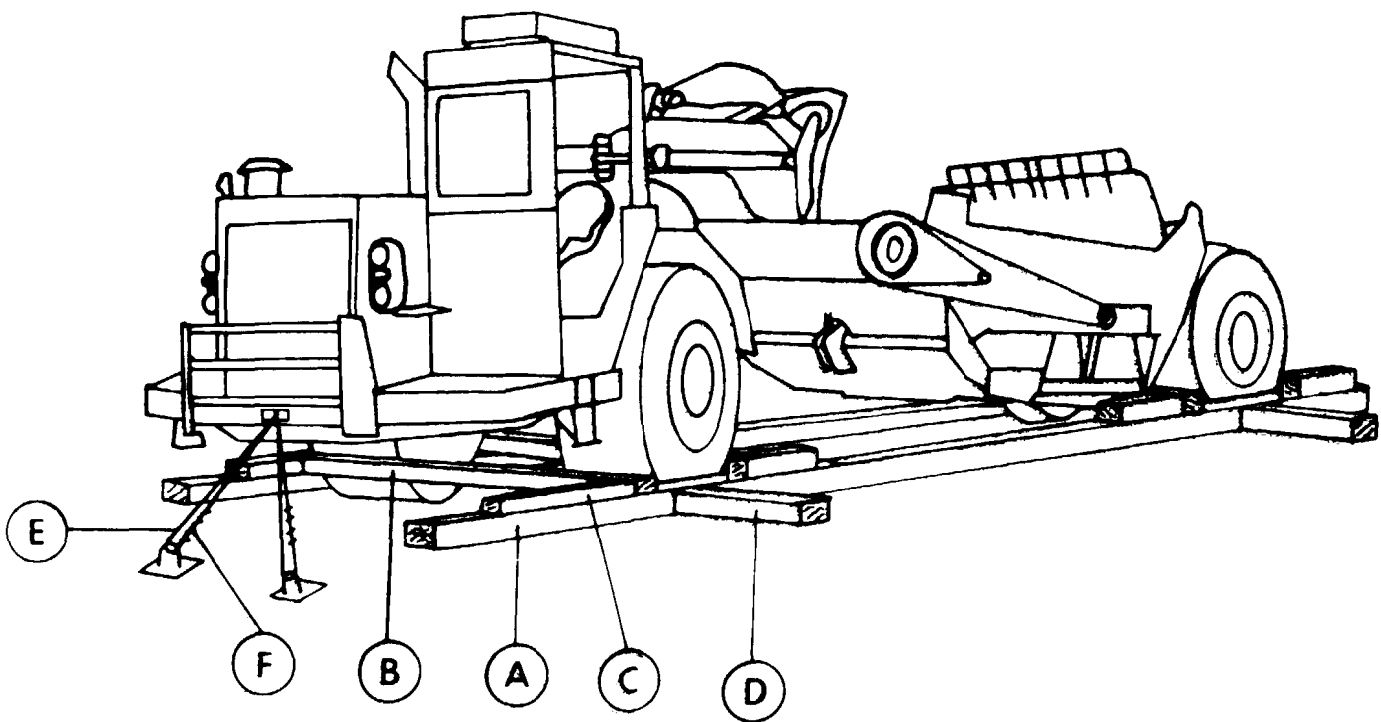

Figure 6-3. Typical bolcking and tiedown of a tractor-scraper in a general cargo vessel.

6-5. Barges and Lighters.

When the tractor-scraper is moved by barge or similar lighterage to or from vessels secured to piers or at a sheltered anchorage, blocking and chocking materials will be required. When the vehicle is moved extended distances or through rough waters, tiedown restraints also must be used.

6-6. Landing Ships, Landing Craft, and Amphibious Vehicles.

When the vehicle is moved from extended distances or through rough waters, blocking and tiedowns must be used. In most cases, the vessels are equipped with turnbuckles with a sheep's foot on one end that fits into a deck cloverleaf; where not provided, a suitable substitute may be used.

Table 6-2. Application of Materials for Blocking and Tiedown of a Tractor-Scraper in Hold of General-Cargo Vessel (fig 6-3).

Item	Description	Approximate Quantity
Lumber	Douglas-fir, or comparable, straight grain. free from material defects: Fed Spec MM-L-751H: 4- x 6-inch 6- x 6-inch	110 linear feet 14 linear feet
Nails	Common, steel: flathead; bright or cement-coated; para 3.6.11.2. Fed Spec FF-N-105B: 30d 40d 60d	40 65 40
Wire rope	Type I. general purpose; class 2, 6 x 19. improved plow steel. wire stand core or IWRC: Fed Spec RR-W-410C: 5/8-inch	100 feet
Clamps	Wire rope, U-bolt clips, saddled. single-grip, forged steel, Crosby heavy duty. or equal; Fed Spec FF-C-450D: 5/8.inch	24

Table 6-2. Application of Materials for Blocking and Tiedown of a Tractor-Scraper. in Hold of General-Cargo Vessel (fig 6-3).

Item	No. Required	Application
A	2	Side blocking for front and rear wheels. 4- x 6,- x 512.inch lumber. Locate at each side of front and rear wheels; position 50 that the side blocking extends slightly beyond the front and rear of the vehicle.
B	4	End Blocking, 6- x 6 x 132.inch lumber. Locate one piece in front and back of front wheels and one piece in front and back of rear wheels. Toenail each end to side blocking with four 60d nails.
C	8	Cleats, 4- x 6- x 24-inch lumber. Locate against blocks (item B) as indicated in figures 6-3. and secure each to side blocking (item A) with five 40d nails.
D	4	Bracing, 4- x 6- x 24-inch lumber, cut-to-fit (or random length as required). Place ends against side blocking on both sides of vehicle and against blocking of other cargo, side of vessel, or other ship's structure, and secure each end with four 30d nails.
E	4	Wire rope. SIX-inch. Run each cable, in a complete loop. through vehicle tiedown points and deck padeyes. Ensure sufficient overlap for clamps.
F	24	Clamp, 5/8-inc. Place six clamps over each cable loop overlap area and space 3-3/4 inches apart. with a minimum of 6 inches from ends of cable Apply 65 foot-pounds of torque to the clamp nuts.

CHAPTER 7

RAIL TRANSPORTABILITY GUIDANCE

Section I. GENERAL

7-1. Scope.

This chapter provides rail transportability guidance for movement of the tractor-scraper, wheeled, M621R. It covers significant technical and physical characteristics, as well as safety concerns, and prescribes the materials and guidance required to prepare, load, tie down, and

unload the vehicle.

7-2. Maximum Utilization of Railcars.

Additional cargo, if approved by the activity offering the items for transport, may be transported with the vehicle. Minimum width of railcars should be 10 feet 4 inches.

Section II. TRANSPORT ON CONUS RAILWAYS

7-3. General.

The transportability guidance contained in this section is applicable when the vehicle is transported on CONUS railways. Consideration is given to single and multiple movements for the types of flatcars normally used for the movement of this vehicle. The vehicle, when loaded on a suitable flatcar, can be transported without sectionalization or major disassembly. The tractor-scraper exceeds width limits for unrestricted movement and will require special routing as determined by officials of the railroad accepting the load.

by a crane, or it may be driven or towed aboard the railcar provided a suitable ramp or bridge is available. When loaded by crane, the procedures and precautions outlined in paragraph 6-46 will be adhered to. During transport, the lockout devices will remain installed, but must be removed if the vehicle is driven or towed off the railcars.

b. Vehicle transmission must be placed in the neutral position and the park brake on (air removed).

c. A typical diagram of a tractor-scraper loaded on a general-purpose flatcar with a minimum width of 10 feet 4 inches is shown in figure 7-1. The type of blocking and tiedown depicted is compatible with standard loading practices and provides adequate restraint against the forces encountered during movements at normal speeds.

d. Table 7-1 is the bill of materials for blocking and tiedown of the tractor-scraper. Table 7-2 provides data for the application of materials required to restrain the vehicle.

7-4. Preparation for loading.

Minimum preparation is required. The procedures of paragraph 5-5 apply.

7-5. Loading of Tractor-Scraper on General-Purpose Flatcars.

a. The vehicle may be placed in the tiedown position on the railcar, approximately centered,

Table 7-1. Bill of Materials for Blocking and Tiedown of the Tractor-Scraper on a General-Purpose Flatcar.

Item	Description	Approximate Quantity
Lumber	Douglas-fir, or comparable, straight grain free from material defects; Fed Spec MM-L-751c:	
	1- x 12-inch	40 linear feet
	2- x 4-inch	42 linear feet
	2- x 6-inch	36 linear feet
	4- x 8-inch	14 linear feet
	3- x 12-inch	24 linear feet
Nails	Common, steel; flathead; bright or cement-coated: para 3.6.11.2. Fed Spec FF-N-105B: 40d	280
Wire Rope	6 x 19. IWRC; improved plow steel; performed, regular-lay; table x, Fed Spec RR-W-410: 5/8-inch	100 feet
Clamps	Wire rope, U-bolt clips, saddled, single-grip, steel, Crosby heavy-duty, or equal: MIL-STD-16842: 5/8-inch	36
Thimbles	Standard, open-type: 5/8-inch	10

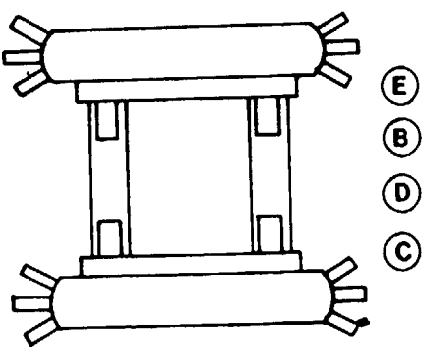
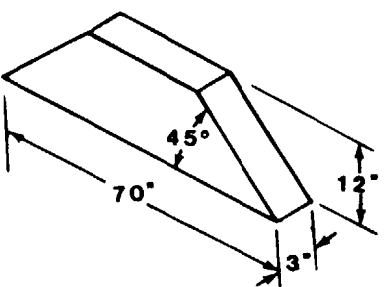
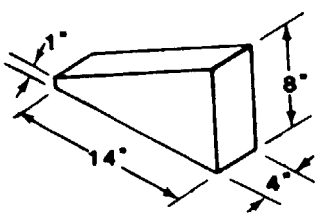
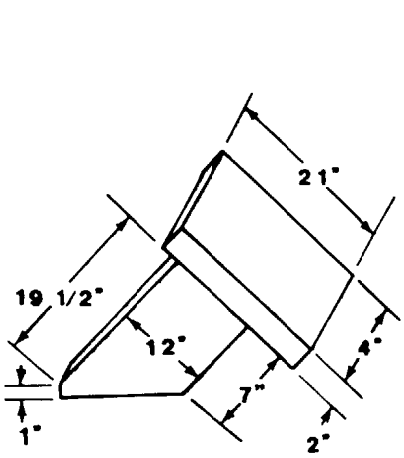
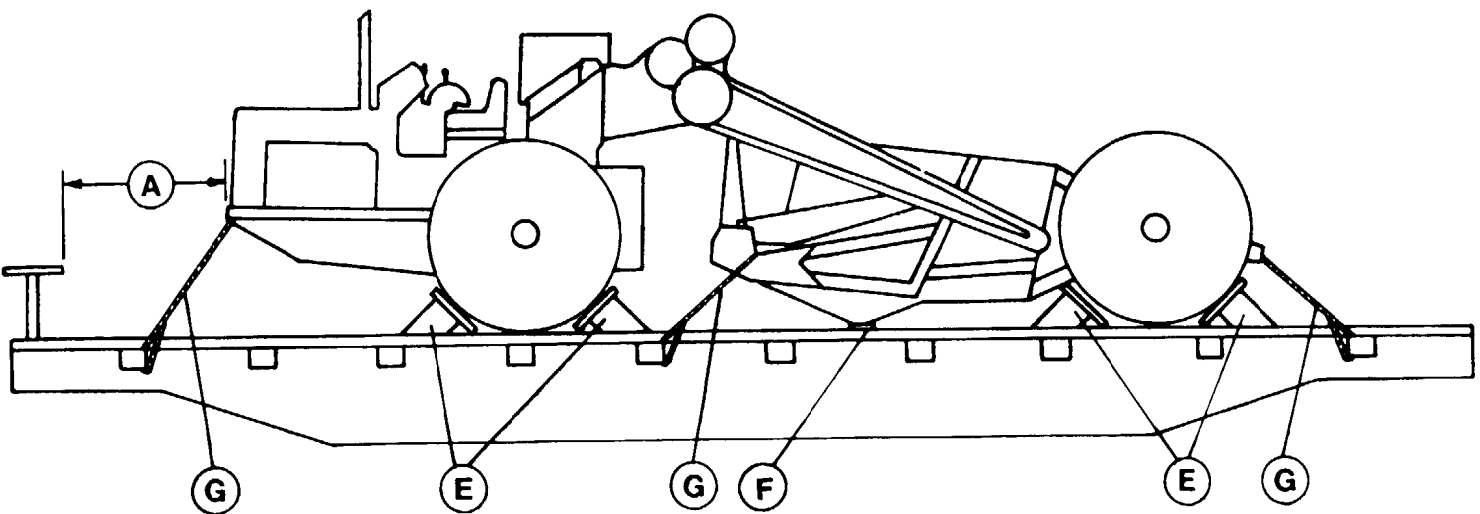

Figure 7-1. Side view of tractor-scraper loaded and restrained on a general-purpose flatcar.

Table 7-2. Application of Materials for Blocking and Tiedown of the Tractor-Scraper on a General-Purpose Flatcar (fig 7-1).

Item	No. Required	Application
A		Brake-wheel clearance. Minimum clearance required is 6 inches above, in back of, and on both sides of, and 4 inches underneath wheel.
B	4	Side blocks. Each to consist of 3- x 12- x 70-inch lumber shaped to pattern B. Locate one inside of each wheel. Secure to floor with two 40d nails on each end.
C	4	Cleats. Each to consist of 2- x 6- x 53-inch (approx) lumber. or length to suit. Locate between side blocks (item B). Secure each to car floor with 40d nails spaced 12 inches apart.
D	8	Blocks. Each to consist of 4- x 8- x 14-inch lumber shaped to pattern D. Locate on top of item C and against item B and secure to both with six 40d nails.
E	24	Chock blocks. Each to consist of a piece of 1- x 12-inch lumber cut to dimensions as shown, and one face plate of 2- x 4- x 21-inch lumber. Locate completed blocks against front and back of each front and rear wheel in the pattern depicted. Secure each to car floor with five 40d nails in each heel and one 40d nail in each side of block.
F	2	Bearing pieces. 4- x 8- x 24-inch lumber. Locate under scraper blade. each side, and secure each to car floor with four 40d nails.
	10	Thimble, open type. 5/8-inch. Place one at bottom of each stake pocket and two on front of tractor, and one each at tiedowns on rear of scraper.
G	5	Wire rope, 5/8-inch. Attach through thimbles on vehicle tiedown devices in a complete loop, across the front cross brace of the scraper bowl, and through the thimble in each stake pocket on the same side of the car at an approximate 45° angle. On chain tiedown cars, chains may be used in lieu of cables.
	36	Clamps, 5/8-inch. Secure the ends of the wire rope with four clamps each. Secure the thimbles with one clamp each.

GENERAL INSTRUCTIONS

Loading rules 1, 2, 3, 4, 5, 7, 9, 14, 15, 19A, and 19B appearing in section I of the *General Rules Governing the Loading of Commodities on Open Top Cars*, published by the Association of American Railroads, provide applicable guidelines and are mandatory in application.

Section III. TRANSPORT ON FOREIGN RAILWAYS

7-6. General.

The transportability guidance contained in this section is applicable when the tractor-scraper is transported on foreign railways. Consideration is given to single and multiple vehicle movements for the types of flatcars normally used for the movement of this type of vehicle. When loaded on a suitable flatcar, the vehicle can be transported, with restrictions, within European countries complying with the passe-partout international (PPI) gauge railways; this also applies to most of the countries in the Middle East, South America, Australia, India, and Pakistan. In the Middle East and South America, the clearances vary by country, and each country will require a separate check. In Australia, India, and Pakistan, wide- or broad-gauge railways provide greater clearances and fewer restrictions. Because of the various

designation systems and clearances used by different countries, evaluation of transport capability must be made on an individual basis.

7-7. Transport on Foreign-Service Flatcars.

a. *General.* The vehicle can be transported on some foreign-service flatcars. Flatcars representative of those available in Europe that are suitable for transporting the vehicle are described in table 7-3.

b. *Materials.* The materials required for blocking and tiedown of the vehicle on foreign-service flatcars are essentially the same as those used for transporting the vehicle within CONUS. Detailed guidance is contained in 4th Transportation Command Pamphlet 55-2, *Tiedown Guide for Rail Movements*.

Table 7-3. Characteristics of European Flatcar A Available for Transporting Vehicles.

Flatcar designation	Capacity	Length	Width	Platform height
RLMMP 700	57.3-ton (52.00 MT)	31-ft 2-in. (9.50-m)	10-ft 4-in (3.15-m)	4-ft 2- 3/4-in. (1.29-m)
SAMS 710	71.63-ton (65.00 MT)	49-ft 3-in. (15.01-m)	10-ft 2-inc. (3.10-m)	4-ft 2- 3/4-in. (1.29-m)

APPENDIX

REFERENCES

A-1. Army Regulations (AR)

55-29	Military Convoy Operations in CONUS
55-80	Highways for National Defense
55-162	Permits for Oversize, Overweight, or Other Special Military Movements on Public Highways in the United States
55-228	Transportation by Water of Explosives and Hazardous Cargo
55-355	Military Traffic Management Regulation
70-44	DOD Engineering for Transportability
70-47	Engineering for Transportability
385-40	Accident Report and Records
746- 1	Packaging of Army Materiel for Shipment and Storage

A-2. Field Manuals (FM)

5-34	Engineer Field Data
5-36	Route Reconnaissance and Classification
55-15	Transportation Reference Data
55-17	Terminal Operations Coordinator's Handbook

A-3. Supply Bulletins (SB)

700-20	Army Adopted/Other Items Selected for Authorization/List of Reportable Items
--------	--

A-4. Technical Bulletins (TB)

55-46-1	Standard Characteristics (Dimensions, Weight, and Cube) for Transportability of Military Vehicles and Other Outsize/Overweight Equipment
---------	--

A-5. Technical Manuals (TM)

55-500	Marine Equipment Characteristics and Data
55-2200-001-12	Transportability Guidance: Application of Blocking, Bracing, and Tiedown Materials for Rail Transport

A-6. Other Publications and Source of Procurement

- a. *Code of Federal Regulations*, Title 49-Transportation, Parts 107-179
Available from: Superintendent of Documents
US Government Printing Office
Washington, DC 20402
- b. Association of American Railroads, *Rules Governing the Loading of Commodities on Open-Top Cars and Trailers*.
Section No. 1-General Rules.
Section No. 6-Rules Governing the Loading of Department of Defense Materiel on Open-Top Cars.
Available from: Association of American Railroads
59 E Van Buren Street
Chicago, IL 60605
- c. M-108 (5/84), *Goodyear Engineering Data for Off-the-Road Tires*.
Available from: Goodyear Tire and Rubber Co.
Technical Center
1144 E. Market Street
Akron, OH 44316-0001

TM 55-3805-248-14

- d. SOMARPI 5-3805-248, *Supplemental Operator's Maintenance and Repair Parts Instruction*.
Available from: TACOM/NMP
AMFTA-MV
Warren, MI 48397-5000

By Order of the Secretary of the Army:

JOHN A. WICKHAM, JR.
General, United States Army
Chief of Staff

Official:

MILDRED E. HEDBERG
Brigadier General, United States Army
The Adjutant General

Distribution:

